



**WEILA**

# **GNSS Positioning Module**

**WKG035BT04Y01**

**User Manual**

## **DISCLAIMER**

The data contained in this manual are derived from laboratory testing by Guangdong Weila Intelligent Technology Co., Ltd. and are for reference purposes only. Actual results may vary.

Guangdong Weila Intelligent Technology Co., Ltd. assumes no responsibility or liability for any use of the information contained herein, including but not limited to any direct or indirect damages, infringements, or losses arising from such use. No warranties, either express or implied, are made with respect to the contents of this manual.

Guangdong Weila Intelligent Technology Co., Ltd. reserves the right to modify or update the contents of this manual at any time without prior notice, in accordance with product version changes and actual conditions.

All trademarks, registered trademarks, and other intellectual property rights referenced in this manual are the property of their respective owners. Unauthorized use of such intellectual property is strictly prohibited.

Guangdong Weila Intelligent Technology Co., Ltd. reserves the right of final interpretation of this manual.

## Table of Contents

### 目录

1. Functional Description .....	4th
1.1. Overview .....	4th
1.2. Key Features .....	4th
1.3. Applications .....	5th
1.4. Assisted GNSS .....	5th
1.5. Output Protocol .....	5th
1.6. Performance Specifications .....	6th
2. Product Description .....	7th
2.1. Module Appearance .....	7th
2.2. Dimensions .....	8th
2.3. Pin Definition .....	8th
3. Electrical Characteristics .....	9th
3.1. Absolute Maximum Ratings .....	9th
3.2. Operating Conditions .....	9th
4. NMEA Protocol .....	10th
4.1. NMEA Protocol Characteristics .....	10th
4.2. Frame Structure .....	10th
4.3. NMEA Identifiers .....	11th
4.4. Support Messages .....	12th
5. Contact Us .....	14th

# 1. Functional Description

## 1.1. Overview

WKG035BT04Y01 is a high-performance GNSS positioning and navigation module with dimensions of 43 × 43 × 11.7 mm. It is based on the AT9850 SoC from Zhongke Micro, a high-performance, low-power dual-frequency multi-constellation GNSS receiver chip. The chip integrates an RF front-end, digital baseband, multi-constellation signal processing engine, and power management, offering high integration and simplified external circuitry.

The module adopts proprietary fast acquisition technology, enabling rapid reception of multiple visible satellite signals for fast and accurate positioning, even in challenging environments such as urban canyons. It features a high-performance embedded CPU and supports a maximum position update rate of up to 10 Hz, making it suitable for high-dynamic and low-latency applications.

With built-in anti-interference hardware acceleration, the module can quickly detect and suppress RF interference. It offers high sensitivity, low power consumption, and cost efficiency, making it ideal for applications such as vehicle navigation, handheld devices, and automotive rearview mirrors.

Utilizing advanced single-chip GNSS SoC technology, the module supports high-precision positioning and timing, while delivering high integration, high performance, and low power consumption. It is widely used in automotive navigation, smartphones, IoT devices, and drones.

## 1.2. Key Features

- Supports L1 and L5 dual-frequency GNSS signal reception
- Supports BDS/GPS/Galileo
- Cold start sensitivity: -148 dBm
- Hot start sensitivity: -156 dBm
- Reacquisition sensitivity: -160 dBm
- Tracking sensitivity: -162 dBm
- Position accuracy: 1m (CEP50)
- TTFF: ≤20s
- Low power consumption (~30mA @5V)
- Stacked Ceramic Antenna (25 × 25 × 4 mm + 35 × 35 × 4 mm)
- Integrated LNA
- Fast hot start (<1.5s) with onboard capacitor

- Standard NMEA-0183 output

## 1.3. Applications

- Automotive rearview mirror systems
- Handheld positioning devices
- Marine and vehicle navigation
- Tracking and location-based services
- Portable electronic devices

## 1.4. Assisted GNSS

Supports A-GNSS, providing assistance data such as ephemeris, approximate position, and time.

This significantly reduces Time-To-First-Fix (TTFF), even in weak signal environments.

## 1.5. Output Protocol

The module outputs data via TTL interface using NMEA-0183 protocol.

## 1.6. Performance Specifications

Parameter	Specification
Signal Reception	BDS: B1I+B1C+B2a; GPS/QZSS: L1+L5 Galileo: E1+E5a; SBAS: L1
RF Channels	88
Cold Start TTFF	<20s
Hot Start TTFF	<1.5s
Reacquisition TTFF	<1s
Cold Start Acquisition Sensitivity	-148dBm
Hot Start Acquisition Sensitivity	-156dBm
Reacquisition Sensitivity	-160dBm
Tracking Sensitivity	-162dBm
Positioning Accuracy	<1m (CEP50)
Velocity Accuracy	<0.05m/s (1 $\sigma$ )
Update Rate	1Hz (max 10Hz)
Baud Rate	115200bps(default)
Interface Protocol	NMEA0183
Power Supply	3.3V – 5.5V
Power Consumption	~30mA @5V
Operating Temperature	-35°C to +85 °C
Storage Temperature	-40°C to +80 °C
Dimensions	43x43x11.7mm

## 2. Product Description

### 2.1. Module Appearance

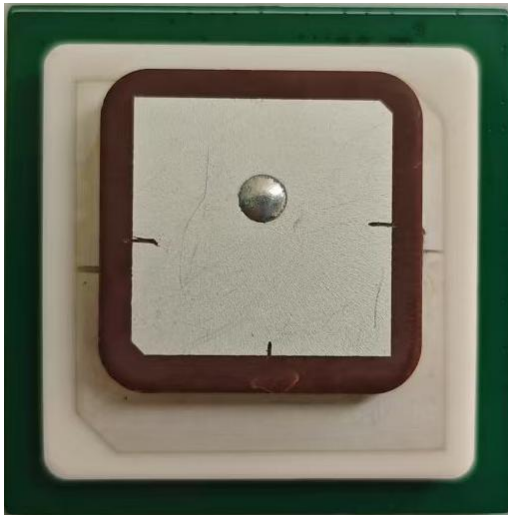

Front



Back

- Stacked ceramic antenna (25 × 25 × 4 mm + 35 × 35 × 4 mm)
- The back side of the module is equipped with a 32.1x27.6x2.7mm shielding cover.
- A supercapacitor on the back provides backup power for the chip, enabling fast hot start.
- 1PPS LED indicator (flashes after positioning fix)
- The back side includes a 5-pin 1.25 mm connector (pin from left to right: GND, RX, TX, 5V, PPS), and is also compatible with a 4-pin 1.25 mm connector (without 1PPS), as well as 5-pin solder pads (pin from left to right: GND, RX, TX, 5V, GND)

## 2.2. Dimensions

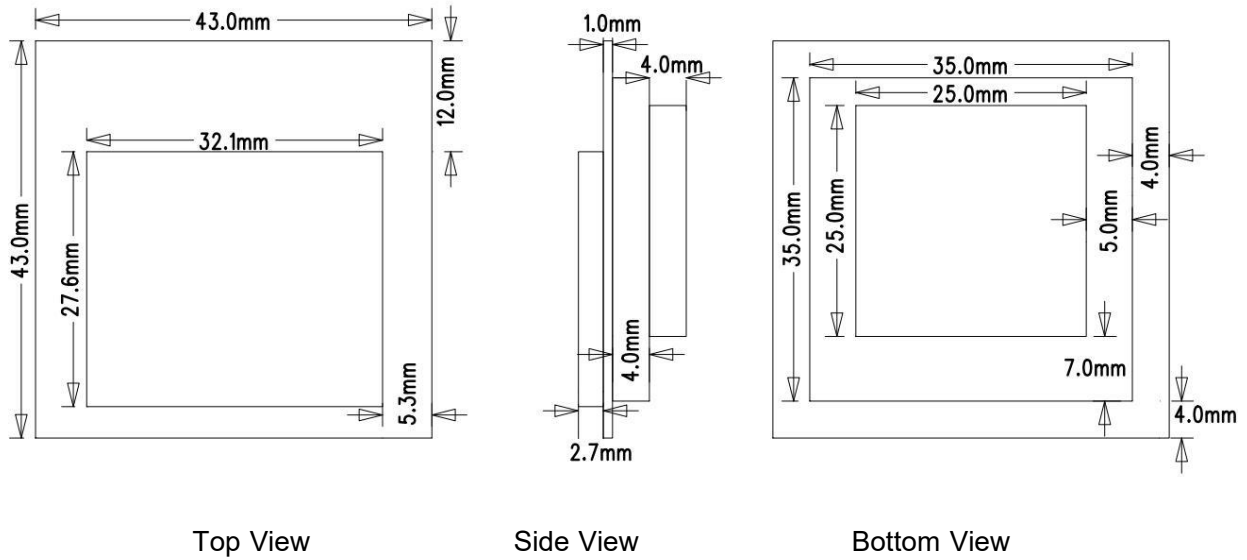

Top View

Side View

Bottom View

## 2.3. Pin Definition

Pin	Type	Description
5V	P	Power supply, 3.3-5.5V
TX	IO	UART output
RT	IO	UART input
1PPS	IO	1PPS Output
GND	P	Ground

## 3. Electrical Characteristics

### 3.1. Absolute Maximum Ratings

Parameter	Symbol	Min	Max	Unit
Voltage	VDD	-0.3	5.5	V
Digital I/O Voltage Level	Tx/Rx/PPS	-0.3	4.1	V
ESD Protection (HBM)	VESD(HBM)	-	2000	V

### 3.2. Operating Conditions

Parameter	Symbol	Min	Typ	Max	Unit
Supply Voltage	VDD	3.3	5	5.5	V
Input Voltage	Vil	-0.3	-	0.6	V
	Vih	2.7	-	3.6	V
Output Voltage	Vol	-	-	0.4	V
	Voh	2.8	-	3.3	V
Average Operating Current	Io @VDD=5V	-	30	-	mA
Operating Temperature	Temp	-35	-	85	°C

## 4. NMEA Protocol

### 4.1. NMEA Protocol Characteristics

WKG035BT04Y01 complies with the international standard NMEA 0183 protocol, as well as a proprietary binary protocol.

The module outputs positioning data such as longitude, latitude, and time via the NMEA 0183 protocol. The proprietary binary protocol is used for module configuration, including parameters such as update rate, baud rate, etc.

Data is transmitted via an asynchronous serial interface. The transmission format consists of a start bit, followed by data bits. The data bits are transmitted in least significant bit (LSB) first order.

Data transmission format:

Start Bit	D0	D1	D2	D3	D4	D5	D6	D7	Stop Bit
-----------	----	----	----	----	----	----	----	----	----------

Data Transmission Parameters:

Baud Rate (bps)	Support 4800、9600、19200、38400、57600、115200
Data Bits	8bits
Stop Bit	1bits
Parity Bit	/

### 4.2. Frame Structure

NMEA Frame Structure				
	Checksum Calculation Range			
\$	<Address >	{, <Data >}	*<Checksum >	<CR><LF>
Start Delimiter	Address Field	Data Field	Checksum Field	End Sequence
Each sentence begins with '\$'	Consists of two parts: Talker ID and Sentence Type	As <input checked="" type="checkbox"/> Begins, contains variable-length or fixed-length data fields	XOR result of all characters between '\$' and '*', represented in hexadecimal	Each sentence ends with <CR><LF>

## 4.3. NMEA Identifiers

NMEA distinguishes different GNSS modes by transmitting different talker IDs, as shown below:

System	ID
BDS	BD
GPS SBAS QZSS	GP
GLONASS	GL
GNSS	GN
Proprietary Information	P

## 4.4. Support Messages

WKG035BT04Y01 supports the following message fields. When multi-GNSS positioning is used, the talker identifier “GN” is applied; otherwise, a single-system identifier is used. An overview of the supported NMEA messages is as follows:

Message	Class/ID	Description
NMEA Standard Message		Standard Message
GGA	0x4E 0x00	Receiver Position Data
GLL	0x4E 0x01	Geographic Position – Latitude / Longitude
GSA	0x4E 0x02	Dilution of Precision (DOP) and Active Satellites
GSV	0x4E 0x03	Satellites in View
RMC	0x4E 0x04	Recommended Minimum Specific GNSS Data
VTG	0x4E 0x05	Speed Over Ground and Course Over Ground
GST	0x4E 0x07	Receiver Pseudorange Error Statistics
ZDA	0x4E 0x08	Time and Date
ANT	0x4E 0x11	Antenna Status
LPS	0x4E 0x12	GNSS System Leap Second Correction Information
DHV	0x4E 0x13	Receiver Velocity Information
UTC	0x4E 0x16	Receiver Status and Simplified Leap Second Correction Information
NMEA Proprietary Messages		Proprietary Messages
CAS00	-	Save Configuration Parameters
CAS01	-	Communication Protocol and UART Configuration
CAS02	-	Set Positioning Update Rate
CAS03	-	Enable or Disable Message Output and Configure Output Frequency
CAS04	-	Set System Initialization and Channel Configuration
CAS05	-	Set NMEA Talker Identifier
CAS06	-	Query Module Software and Hardware Information
CAS10	-	Startup Mode and Assisted Data Configuration
CAS12	-	Standby Mode Control
CAS20	-	Firmware Upgrade Command (OTA Supported)

Among all supported NMEA messages, RMC is the most commonly used. It provides essential information including longitude, latitude, UTC time, and positioning status.

The TXT message provides additional information such as manufacturer identification, software and hardware versions, firmware release date, and antenna status (open, connected, or short circuit).

## 5. Contact Us

**Company:** Guangdong Weila Intelligent Technology Co., Ltd

**TEL:** 13602688458 (Mr. Zeng)

**Email:** [sales@weikengtech.com](mailto:sales@weikengtech.com)

**ADD:** Floor 11, Block A, Building 9, Baoneng Science and Technology Park,  
Qingxiang Road, Longhua District, Shenzhen

